

## 18ROGI-PVDF\* - RACCORDI AD ANELLO PVDF

### STRAIGHT END FITTINGS WITH TAPER GAS

Pipe external diameter	Thread	CODE	
6	1/4"	18ROGI-PVDF-ED1/4X06	9
10	1/2"	18ROGI-PVDF-ED1/2X10	2
12	1/2"	18ROGI-PVDF-ED1/2X12	2



### ELBOW END FITTING WITH TAPER GAS

Pipe external diameter	Thread	CODE	
10	1/2"	18ROGI-PVDF-EG1/2X10	2

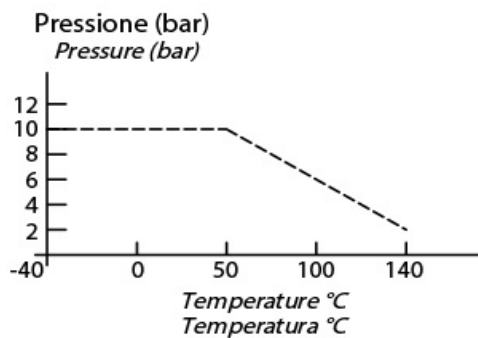

- a tube
- b nut
- c conical ring
- d washer
- e fluorinated elastomer gasket
- f fitting body

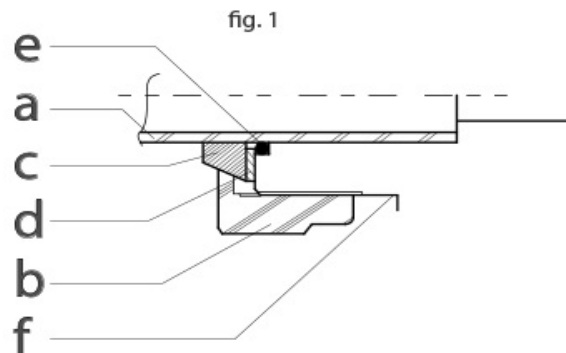

### ASSEMBLY

- 1 – Cut the tube cleanly and precisely;
- 2 – Insert into the tube in succession:
  - nut
  - conical ring
  - washer
  - gasket (must slide with light friction on the pipe)
- 3 – Insert the pipe into the fitting up to the stop;
- 4 – Screw and tighten the nut by hand;
- 5 – Tighten the nut with the wrench, preferably a torque wrench.



**SATEMA**

13856 VIGLIANO B.SE - Via Milano, 395

Tel. +39 015811102

Mail: [info@satema.it](mailto:info@satema.it)

<http://www.satema.it>