

## MAGPE 75 - LOW FLOW MAGMETER

The MAGPE75 magmeter is designed for low-flow chemical injection or difficult-to-meter applications with pulsating metering pumps in 3/4" to 1/2" pipe/tube. The housing is made of sturdy splashproof HDPE plastic.

With no moving parts, the MAGPE75 can handle fluids containing particulate matter without clogging or jamming, keeping maintenance at a minimum. With no metallic parts (100% PVDF body and PVDF carbon fiber-filled electrodes), the meter is corrosion-resistant and compatible with a wide range of chemicals. Accuracy is maintained with conductive fluids (>20 microSiemens) of varying viscosities and densities.

The MAGPE75 meter is compact enough to fit most pump/injection systems. With zero straight pipe required after an elbow, it can be easily mounted in tight spaces. The mounting bracket adds stability.



## TECHNICAL SPECIFICATIONS

Pipe size:	3/4" - 1/2"
Process connections:	1/2" BSP male
Body material:	PVDF
Electrodes, ground :	PVDF carbon fiber-filled
Fittings:	PVDF
Housing:	HDPE with glass fiber
Ambient temperature:	-18...+54°C
Fluid temperature:	0...93°C
Pressure:	10 bar max
Flow rate:	0,75...75 lt/min
Accuracy:	+/- 1% + 0,0018% of reading across rated range
Output:	frequency 500 pulses/liter; or analog 4/20 mA
Power supply:	10...15 Vdc, 150 mA (linear power supply recommended)
Conductivity:	> 20 microSiemens
Empty pipe detection:	self detect
Protection:	NEMA 4X standard, IP66
Accessories:	REG311D - Visualizzatore-regolatore elettronico di portata

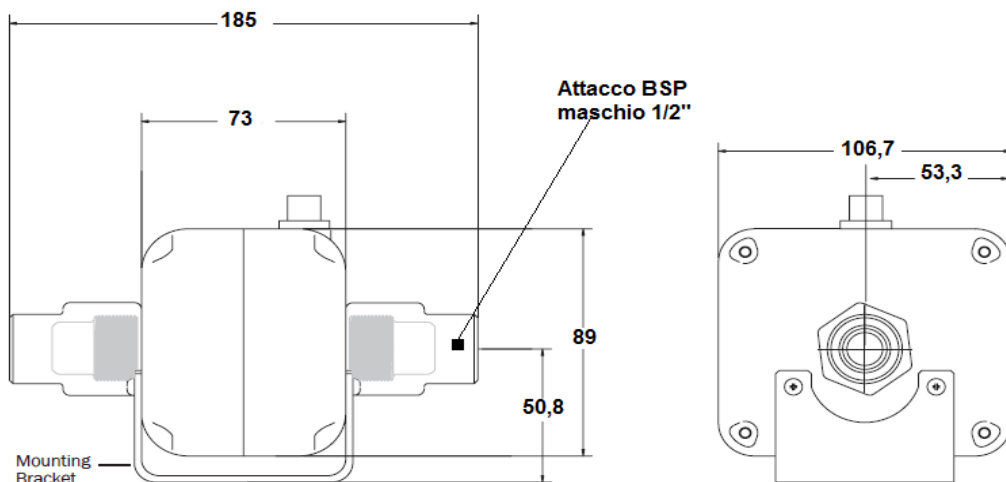

MAGPE75



**SATEMA**

13856 VIGLIANO B.SE - Via Milano, 395

Tel. +39 015811102 - Fax 0158853029

Mail: [info@satema.it](mailto:info@satema.it) <http://www.satema.it>

## MAGPE 75 - LOW FLOW MAGMETER

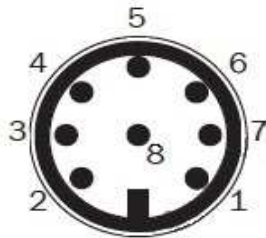

**Presa femmina lato cavo**

**Female cable plug**

Pin#	Function	Color
1	Impulso/Pulse (-)	Bianco White
2	Massa/Ground	Marrone Brown
3	Impulso/Pulse (+)	Verde Green
4	4-20 (+)	Giallo Yellow
5	non usato/not used	Grigio Grey
6	non usato/not used	Rosa Pink
7	4-20 (-)	Blu Blue
8	Alimentazione/Supply	Rosso Red

**Misuratore con 4/20 mA e REGFT420 con alimentazione singola**  
**4/20mA device and REGFT420 with single power supply**

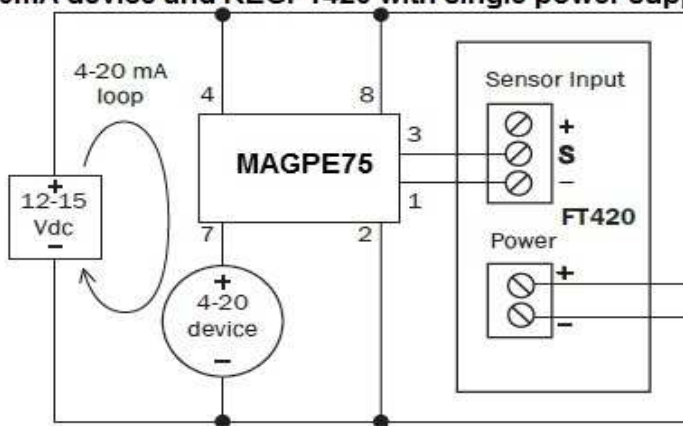

**uscita impulsi e REG 311D**  
**Pulse output and REG 311D**

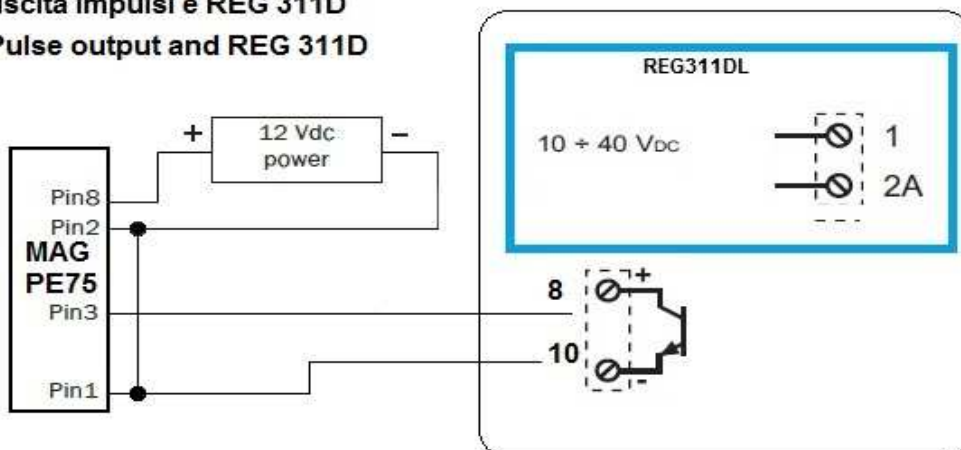

**SATEMA**

13856 VIGLIANO B.SE - Via Milano, 395

Tel. +39 015811102 - Fax 0158853029

Mail: [info@satema.it](mailto:info@satema.it) <http://www.satema.it>