

SCOVE OVAL BODY GATE VALVE - OUTSIDE SCREW PN25-40

Carbon steel body, bonnet and wedge. Pressed steel handwheel. Stainless steel stem and sealing seats. Graphite + stainless steel gaskets. Connection flanges dressed and drilled according to EN-1092-1 PN40-25 with raised face.

On request:

- Bigger sizes
- Flanges with special drilling
- Stainless steel execution
- Chain wheel for remote manoeuvre



DIMENSIONS

PN	DN	D	L	H	H1	V	KG	Kv
	mm	mm	mm	mm	mm	mm		m ³ /h
40	50	165	250	340	400	200	23	228
40	65	185	270	360	435	200	31	380
40	80	200	280	410	500	200	36	589
40	100	235	300	500	610	250	53	939
40	125	270	325	535	670	250	73	1554
40	150	300	350	615	780	250	98	2250
25	200	360	400	720	935	300	150	4020
25	250	425	450	975	1240	400	230	6340
25	300	485	500	1045	1360	500	330	9235
25	350	555	550	1250	1615	500	400	12542
25	400	620	600	1410	1830	500	600	16378

WORKING CONDITIONS

DN (mm)	Allowable pressure bar	Max working temperature related to the pressure
50-150	40	-10...+50°C
50-150	30,2	+200°C
50-150	23,1	+400°C
200-400	25	-10...+50°C
200-400	19,4	+200°C
200-400	14,4	+400°C

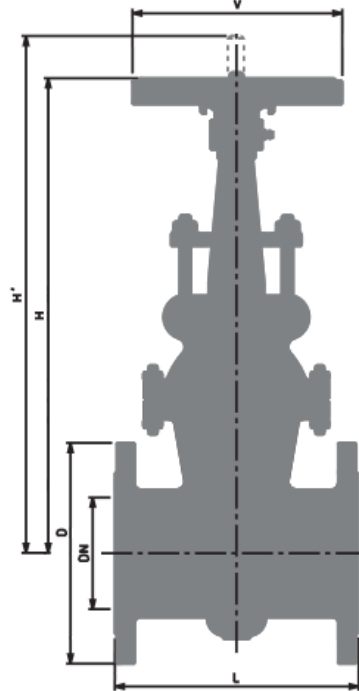

SATEMA

13856 VIGLIANO B.SE - Via Milano, 395

Tel. +39 015811102 - 015510156 - Fax 0158853029

Mail: info@satema.it <http://www.satema.it>

CONSTRUCTION

ITEM	PART NAME	MATERIAL
1	BODY	GP 240 GH+N STEEL
2	BONNET	GP 240 GH+N STEEL
3	RING	GP 240 GH+N STEEL
4	STEM	STAINLESS STEEL
5	WEDGE	GP 240 GH+N STEEL
6	HANDWHEEL	PRESSED STEEL
7	TIE-ROD	STEEL
8	NUT	STEEL
9	WEDGE SEAT	STAINLESS STEEL
10	BODY SEAT	STAINLESS STEEL
11	GASKET	GRAPHITE+ST. STEEL
12	LUBRICATOR	ZINC PLATED STEEL
13	PACKING	GRAPHITE+ST. STEEL
14	GLAND	CARBON STEEL
15	BUSH	STEEL
16	ELASTIC RING	STEEL
17	MOTHERSCREW	STEEL

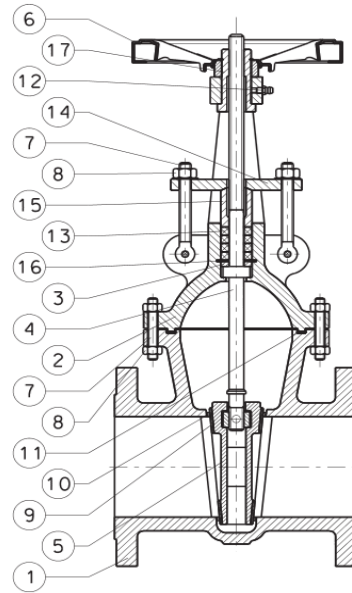

SATEMA

13856 VIGLIANO B.SE - Via Milano, 395

Tel. +39 015811102 - 015510156 - Fax 0158853029

Mail: info@satema.it <http://www.satema.it>