

GRJSX* GIUNTI ROTANTI

SXA	K *	3/4"	1"	1"1/4	1"1/2	2"	2"1/2	3"
	M	3/4"	1"	1"1/4	1"1/2	2"	2"1/2	3"
	C	93,73	104,65	133,35	166,62	176,28	198,37	218,95
	F	50,8	45,97	50,8	55,63	57,15	66,55	76,2
	G	111,25	122,17	150,88	177,8	203,71	214,63	247,9
	J	184,15	195,33	232,92	266,7	301,75	319,53	389,13
	O	10,67	11,18	14,22	18,28	22,35	22,35	27,69
	RPM	550	450	350	300	250	200	150

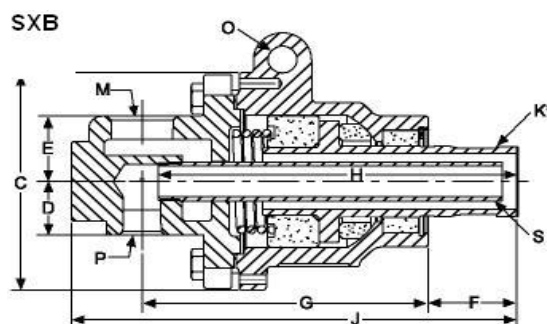
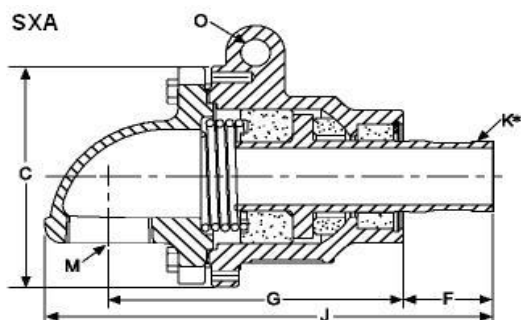

SXB	K *	3/4"	1"	1"1/4	1"1/2	2"	2"1/2	3"
	M	1/2"	3/4"	1"	1"1/4	1"1/2	2"	2"1/2
	P	1/2"	1/2"	1/2"	3/4"	3/4"	1"	1"1/4-1"1/2
	S	1/8" - 1/4"	1/4" - 3/8"	3/8" - 1/2"	1/2" - 3/4"	1/2" - 3/4"	3/4" - 1"	3/4"-1"1/2
	C	93,73	104,65	133,35	166,62	176,28	198,37	218,95
	D	19,05	28,45	35,05	36,58	38,1	38,1	73,15
	E	33,27	35,05	45,97	44,45	47,75	52,32	90,42
	F	50,8	45,97	50,8	55,63	57,15	66,55	76,2
	G	115,82	127	165,1	180,85	196,85	209,55	264,16
	H	152,4	171,45	196,85	225,55	241,3	261,62	304,8
	J	200,15	227,08	265,18	279,4	311,91	345,44	422,66
	O	10,67	11,18	14,22	18,28	22,35	22,35	27,69
	RPM	550	450	350	300	250	200	150

SXB2	K *	3/4"	1"	1"1/4
	M	1/2"	3/4"	1"
	P	3/8"	1/2"	1/2"
	S	1/8"	1/4" - 3/8"	3/8"
	C	93,73	104,65	133,35
	D	23,88	26,92	-
	E	33,27	35,05	39,62
	F	50,8	45,97	50,8
	G	115,82	125,48	165,1
	H	156,97	162,05	214,12
	J	188,72	195,33	233,68
	O	10,67	11,18	14,22
	RPM	550	450	350

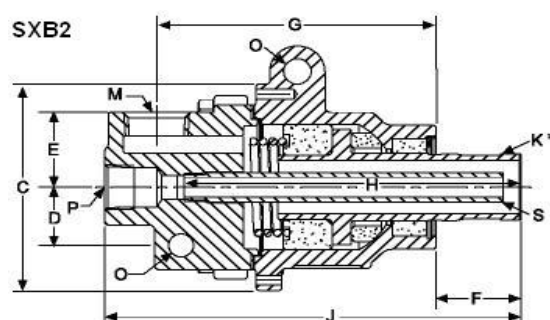

SATEMA

13856 VIGLIANO B.SE - Via Milano, 395

Tel. +39 015811102 - 015510156 - Fax 0158853029

Mail: info@satema.it <http://www.satema.it>

GRJSX* GIUNTI ROTANTI

SXC	K *	3/4"	1"	1"1/4	1"1/2	2"	2"1/2	3"
	M	3/4"	1"	1"1/4	1"1/2	2"	2"1/2	3"
	C	93,73	104,65	133,35	166,62	176,28	198,37	218,95
	F	50,8	45,97	50,8	55,63	57,15	66,55	76,2
	G	111,25	122,17	150,88	177,8	203,71	214,63	247,9
	J	184,15	195,33	232,92	266,7	301,75	319,53	389,13
	O	10,67	11,18	14,22	18,28	22,35	22,35	27,69
	RPM	550	450	350	300	250	200	150

SXD	K *	1"1/2	2"	2"1/2	3"
	M	1"1/4	1"1/2	2"	2"1/2
	P	3/4"	3/4"	1"	1"1/4- 1"1/2
	S	1/2" - 3/4"	1/2" - 3/4"	3/4"	1" - 1"1/2
	C	166,62	176,28	198,37	218,95
	D	173,74	188,47	208,53	240,79
	E	44,45	47,75	52,32	60,45
	F	55,63	57,15	66,55	76,2
	G	57,15	60,45	60,96	88,9
	H	281,18	284,99	335,03	375,92
	J	322,33	336,3	382,52	442,47
	O	18,28	22,35	22,35	27,69
	RPM	300	250	200	150

SXC

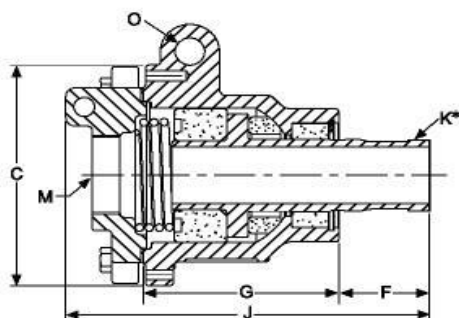

SXD

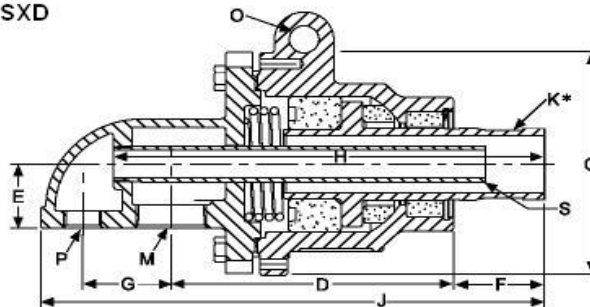

CARATTERISTICHE TECNICHE

Fluidi: acqua surriscaldata, vapore, olio diatermico (specificare)
 Pressione/temperatura esercizio: acqua surr./vapore 20 bar - 288°C
 olio diatermico 10 bar - 343°C
 rotazione (K *): specificare se destro, sinistro, o a flangia rapida "Q"



SATEMA

13856 VIGLIANO B.SE - Via Milano, 395
 Tel. +39 015811102 - 015510156 - Fax 0158853029
 Mail: info@satema.it <http://www.satema.it>